

# LABORATORY MANUAL

Class XII

# PHYSICS

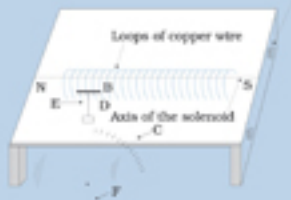
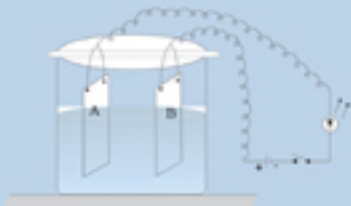

## EXPERIMENTS

# EXPERIMENT 1

### AIM

To determine resistance per unit length of a given wire by plotting a graph of potential difference versus current.

### APPARATUS AND MATERIAL REQUIRED

A wire of unknown resistance ( $\sim 10\Omega$ ), battery eliminator or an accumulator (0 to 3V) or two dry cells (1.5 V each), voltmeter (0-5 V), milliammeter (0-500 mA), rheostat, plug key, connecting wires and a piece of sand paper.

### PRINCIPLE

Ohm's law states that the electric current flowing through a conductor is directly proportional to the potential difference across its ends, provided the physical state of the conductor remains unchanged.

If  $I$  be the current flowing through the conductor and  $V$  the potential difference across its ends, then according to Ohm's law

$$V \propto I$$

and hence

$$V = RI$$

(E 1.1)

where  $R$  is the constant of proportionality and is termed as the electrical resistance of the conductor. If  $V$  is expressed in volts and  $I$  in amperes, then  $R$  is expressed in ohms. The resistance  $R$ , depends upon the material and dimensions of the conductor. For a wire of uniform cross-section, the resistance depends on the length  $l$  and the area of cross-section  $A$ . It also depends on the temperature of the conductor. At a given temperature the resistance

$$R = \frac{l}{A}$$

(E 1.2)

where  $\rho$  is the specific resistance or resistivity and is characteristic of the material of wire.

Combining Eqs. (E 1.1) and (E 1.2) we have

$$(E 1.3) \quad V = \frac{l}{A} I$$

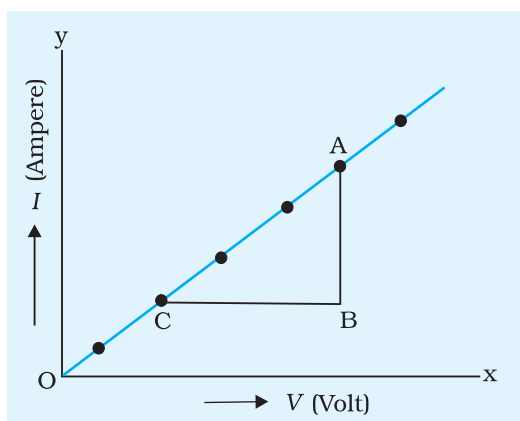

**Fig. E 1.1** Graph between current  $I$  and potential difference,  $V$

A linear relationship is obtained between  $V$  and  $I$ , i.e. the graph between  $V$  and  $I$  will be a straight line passing through the origin as shown in Fig. E 1.1. The slope of the graph is  $1/R$  from Eq. (E 1.1) (Equation of straight line passing through origin is  $y = mx$  where  $m$  is the slope of graph).

$$\text{Slope} = \frac{1}{R}$$

$$\Rightarrow R = \frac{1}{\text{slope}}$$

If  $l$  is the length of wire then the resistance per unit length of the wire  $\frac{R}{l}$ .

## PROCEDURE

1. Clean the ends of the connecting wires with the help of sand paper in order to remove any insulating coating on them.
2. Connect various components - resistance, rheostat, battery, key, voltmeter and ammeter as shown in Fig. E 1.2.

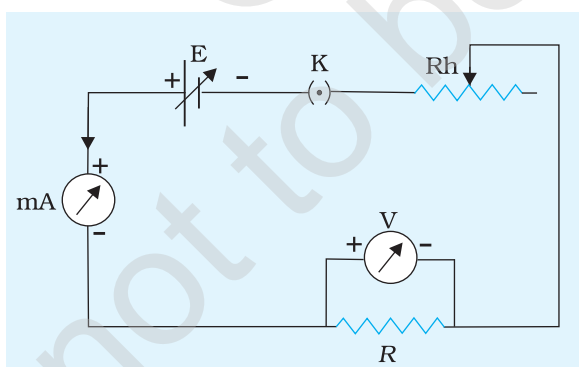

**Fig. E 1.2** Circuit to find the relation between current  $I$  and potential difference,  $V$  for a given wire

3. Note whether pointers in milliammeter and voltmeter coincide with the zero mark on the measuring scale. If it is not so, adjust the pointer to coincide with the zero mark by adjusting the screw provided near the base of the needle using a screw driver.
4. Note the range and least count of the given voltmeter and milliammeter.
5. Insert the key  $K$  and slide the rheostat contact to one of its extreme ends, so that current passing through the resistance wire is minimum.
6. Note the milliammeter and voltmeter readings.

## EXPERIMENT 1

7. Remove the key K and allow the wire to cool, if heated. Again insert the key. Shift the rheostat contact slightly to increase the applied voltage. Note the milliammeter and voltmeter reading.
8. Repeat step 7 for four different settings of the rheostat. Record your observations in a tabular form.

### OBSERVATIONS

1. Range of ammeter = 0 ... mA to ...mA
2. Least count of ammeter = ... mA
3. Range of voltmeter = 0 ... V to ...V
4. Least count of voltmeter = ...V
5. Least count of metre scale = ... m
6. Length of the given wire,  $l = \dots\text{m}$

**Table E 1.1: Voltmeter and milliammeter readings**

| Sl. No. | Applied potential difference<br>[voltmeter reading $V$ (V)] | Current flowing through the wire<br>[milliammeter reading $I$ (mA)] |
|---------|---|---|
|         | $V$   | $I$   |
| 1       |   |   |
| 2       |   |   |
| --      |   |   |
| 6       |   |   |

### CALCULATIONS

1. Plot a graph between the potential difference across the wire ( $V$ ) and the current ( $I$ ) flowing through it as shown in Fig. E 1.1.
2. Determine the slope of the graph. The resistance of the given wire is then equal to the reciprocal of the slope.

From the graph  $R = \frac{BC}{AB} \dots \Omega$

3. Resistance per unit length of given wire =  $\frac{R}{l} = \dots \Omega \text{ m}^{-1}$

#### **Error**

$$\frac{R}{R} = \frac{V}{V} = \frac{I}{I} = \dots$$

(E 1.4)

Here,  $R$  is resistance per unit length and  $\Delta R$  is estimated error.  $\Delta V$  and  $\Delta I$  are the least count of the voltmeter and milliammeter respectively.

## RESULT

1. The potential difference across the given wire varies linearly with the current.
2. The resistance per unit length of the wire is  $(R \pm \Delta R)$   
= (... ..  $\Omega\text{m}^{-1}$ ).

## PRECAUTIONS

1. The voltmeter should be connected in parallel and the ammeter in series with the circuit. It should be ensured that current enters at the positive terminal and leaves at the negative terminal.
2. The key should be inserted only while taking observations, as excessive flow of current causes unnecessary heating of the wire.
3. Zero error in measuring instruments (voltmeter, ammeter, metre scale) must be taken cognizance of and should be eliminated in case of ammeter and voltmeter by adjusting the pointer with the help of the screw provided at the base of the needle, using a screw driver.

## SOURCES OF ERROR

1. The wire used may not be of uniform area of cross-section.
2. The length of the resistance wire measured should be between one terminal of voltmeter and the other. The lengths of ends wound around the terminals of voltmeter, if included, would give error in measured length.

## DISCUSSION

A resistor obeys Ohm's law. However, not all conducting devices obey Ohm's law e.g. diode, thyristor etc. These are called non-ohmic resistances.

## SELF ASSESSMENT

1. A voltmeter is always connected in parallel and an ammeter in series with the circuit. Why? Will they record the respective parameters if connected in opposite manner?